

| Rev | Description | By | Date      |
|-----|-------------|----|-----------|
| 1   | Preliminary | TM | 22-Oct-20 |

### ELECTRICAL SPECIFICATIONS @ 25°C

L(per wdg): 5.9mH Min @ 10kHz, 0.1Vrms  
 DCR(per wdg): 7.0 mΩ Max  
 Irms: ΔT≤40°C @14A  
 Turns Ratio: 1:1:1±0T  
 (1-2):(3-4):(5-6)  
 Polarity: 1, 3 and 5 are in phase  
 Hipot: 2kVac, 1mA Max, 10s (wdg to wdg)  
 Operating Temperature: -40 °C to +125 °C  
 RoHS Compliant: Yes

### DIMENSIONS

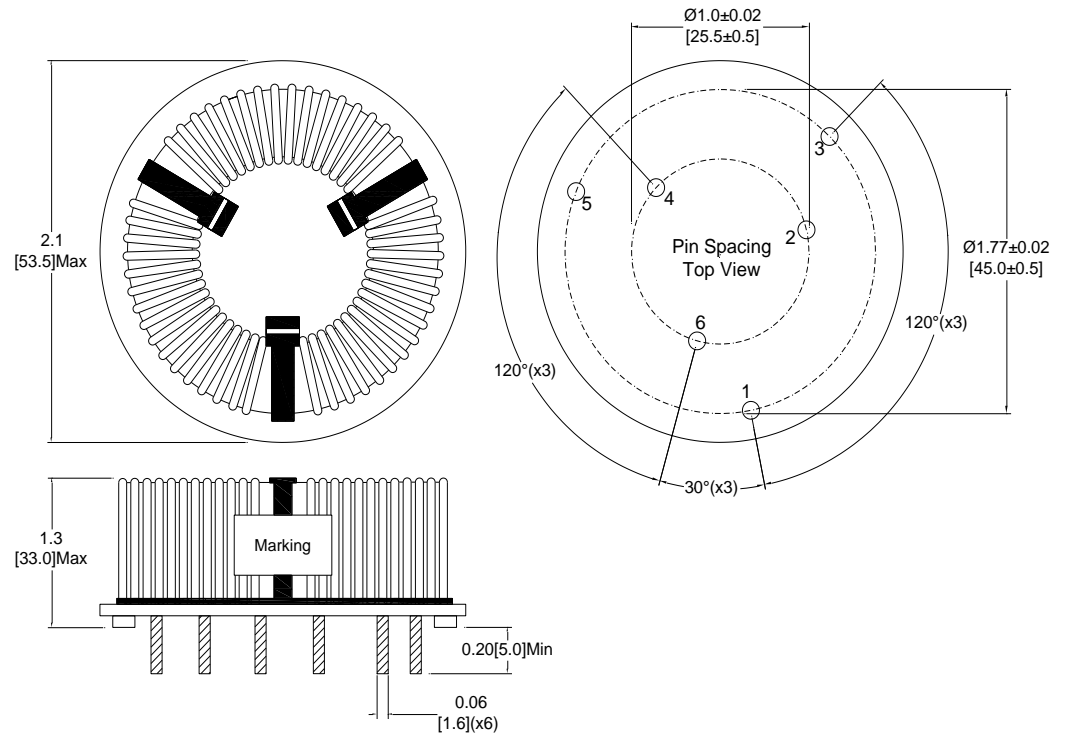

### SCHEMATIC

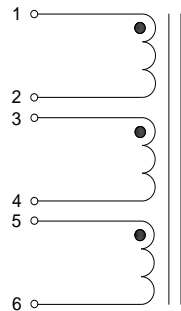

### MARKING

MPS  
 P57TP40H-592\_Rev  
 Date Code

Dimensions: inch/[mm]

|                                                                                                                                                                                                                                       |  |                          |          |                                                                                                                                                                                                                    |                  |                                    |                 |
|---------------------------------------------------------------------------------------------------------------------------------------------------------------------------------------------------------------------------------------|--|--------------------------|----------|--------------------------------------------------------------------------------------------------------------------------------------------------------------------------------------------------------------------|------------------|------------------------------------|-----------------|
| <b>Notice of Proprietary Property</b><br>These drawings and specifications are the property of MPS and shall not be reproduced, copied or used as the basis of manufacture of sale of apparatus without express written authorization |  |                          |          |  <b>MPS INDUSTRIES, INC.</b><br><a href="http://www.mpsind.com">www.mpsind.com</a><br>Tel: (310) 325-1043 Fax: (310) 325-1044 |                  |                                    |                 |
|                                                                                                                                                                                                                                       |  |                          |          |                                                                                                                                                                                                                    |                  | Description                        |                 |
|                                                                                                                                                                                                                                       |  |                          |          | <b>3-Phase CMC</b>                                                                                                                                                                                                 |                  |                                    |                 |
| <b>Dimensions</b><br>Unless otherwise specified<br>.XX ± .010" [0,254mm]<br>.XXX ± .005" [0,13mm]                                                                                                                                     |  | DRAWN BY:<br>CHECKED BY: | TM<br>AG | 22-Oct-20<br>27-Oct-20                                                                                                                                                                                             | SIZE<br><b>A</b> | Part Number<br><b>P57TP40H-592</b> | REV<br><b>1</b> |
|                                                                                                                                                                                                                                       |  |                          |          | WEIGHT: 90 gms                                                                                                                                                                                                     |                  | SHEET: 1 OF 1                      |                 |