

Rev	Description	By	Date
A	Released Production	TM	16-Oct-20

ELECTRICAL SPECIFICATIONS @ 25°C

Part No	Turns Ratio ±3%	Insertion Loss (dB) Max MHz		Return Loss (dB) Min MHz		Cross talk (dB) Typ MHz		CDMR (dB) Typ MHz			DCMR (dB) Typ MHz		CMR (dB) Typ MHz
		1-50	50-125	1-40	40-200	1-125	125-200	1-50	50-100	100-200	1-10	10-200	1-125
N5459	1CT:1CT	-0.5	-1.0	-20	-9.5	-30	-25	-30	-27	-24	-48	-23	-35

Inductance: 180µH Min @100KHz/0.1V@8mA
 Inductance: 150uH MIN @100KHz/0.1V@11mA
 Inductance: 120uH MIN @100KHz/0.1V@19mA
 Hipot (Pri to Sec): 1500Vrms/0.5mA/60Sec
 POE applications current capability: 720mA
 RoHS: Yes

DIMENSIONS

SCHEMATIC

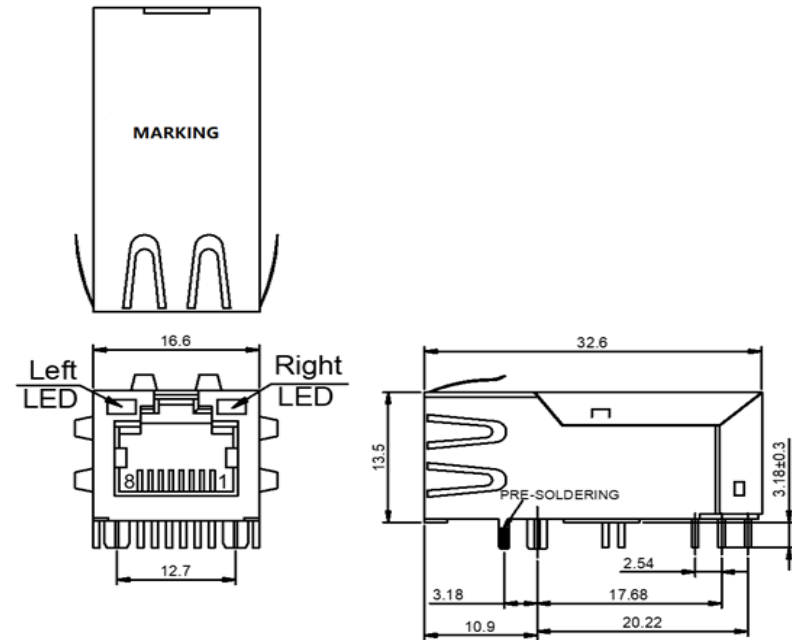
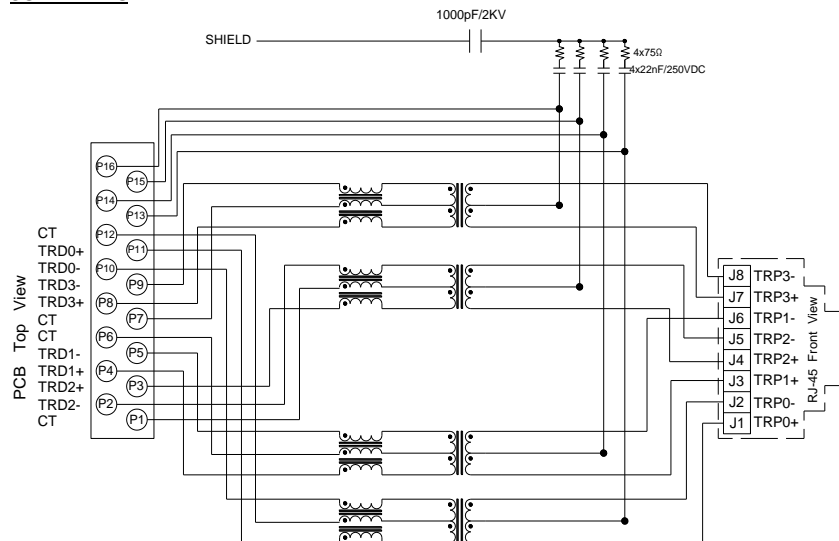

Dimensions: mm

MARKING LABEL

N5459_Rev
 MPS
 DATE CODE

Notice of Proprietary Property
 These drawings and specifications are the property of MPS and shall not be, reproduced, copied or used as the basis of manufacture of sale of apparatus without express written authorization

Dimensions Unless otherwise specified .XX ± .010" [0,254mm] .XXX ± .005 [0,13mm]	DRAWN BY: CHECKED BY:	TM TC	16-Oct-20 23-Oct-20	SIZE A
--	--------------------------	----------	------------------------	------------------

		MPS INDUSTRIES, INC. www.mpsind.com Tel: (310) 325-1043 Fax: (310) 325-1044	
Description		2.5GBase-T POE+ Single Port Rj45 Integrated Connector Module	
Part Number	N5459		REV A
WEIGHT: XX gms		SHEET: 1 OF 2	

Rev	Description	By	Date
A	Released Production	TM	16-Oct-20

PACKING INFORMATION

- 1. packaging unit : 60 PCS/tray
- 2. packaging material : PET

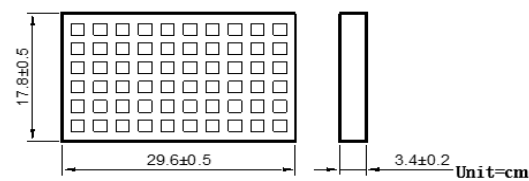

- 3. outer carton unit: 840 pcs/ 14 Trays/box
- 4. Weight: 11.0kg per carton

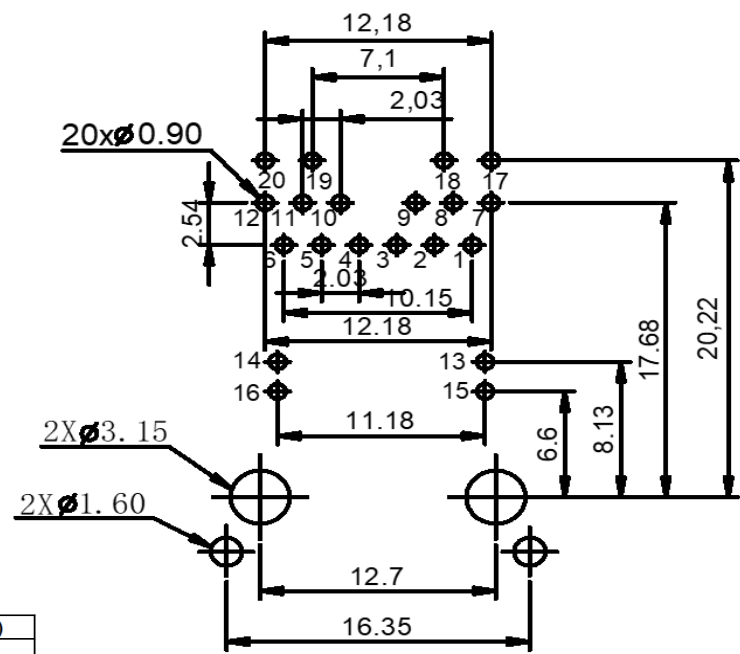
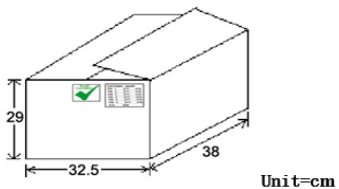

COMPONENT SIDE VIEW
LANDED PATTERN

MATERIAL SPECIFICATION

Housing	Insert	Contact	Shield	Plate (if applicable)
NYLON86 UL94V-0 STANDARD COLOR:BLACK	QSn6.5-0.1---0.35mm Thickness PLATING(1) NICKEL PLATING(2) 100%Sn PLATING(3) GOLD (6u *)	QSn6.5-0.1---0.35mm Thickness PLATING(1) NICKEL PLATING(2) 100%Sn	BRASS H65Y PLATING NICKEL	PBT+30%GF UL 94V-0
Operating Life(MIN)	Storage Temperature	Operating Temperature		
750 Cycles MIN	-40°C TO +85°C	0°C TO +70°C		



Standard LED	Wavelength	Forward*V(MAX)	TYP
Green	565nm	2.5v	2.2v
Yellow	585nm	2.5v	2.1v

With a forward current of 20mA

Notice of Proprietary Property

These drawings and specifications are the property of MPS and shall not be, reproduced, copied or used as the basis of manufacture of sale of apparatus without express written authorization

Dimensions Unless otherwise specified .XX ± .010" [0,254mm] .XXX ± .005 [0,13mm]	DRAWN BY: CHECKED BY:	TM TC	16-Oct-20 23-Oct-20
--	--------------------------	----------	------------------------

		MPS INDUSTRIES, INC. www.mpsind.com Tel: (310) 325-1043 Fax: (310) 325-1044	
Description			
2.5GBase-T POE+ Single Port RJ45 Integrated Connector Module			
Part Number	N5459		REV
	WEIGHT: XX gms		SHEET: 2 OF 2