

Rev	Description	By	Date
B	Released for Production	MIG	17-Mar-16
C	Updated pin dimensions and DC bias graph	AG	21-Sep-20

### ELECTRICAL SPECIFICATIONS @ 25°C

L:	24μH±15% @ 10kHz, 1Vrms
Isat:	ΔL ≤ 10% @ 38A ΔL ≤ 30% @ 72A
Irms:	ΔT ≤ 20°C @ 40A ΔT ≤ 40°C @ 60 A
DCR:	1.9mΩ Max
Hipot:	500Vdc, 1mA Max, 5s, wdg to core
Insulation Class:	Class H 180°C
RoHS Compliant:	Yes

### SCHEMATIC

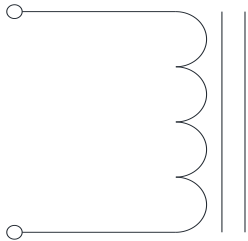

### MARKING

MPS  
HWI4434-060A-240H\_REV#  
Date Code

### DIMENSIONS

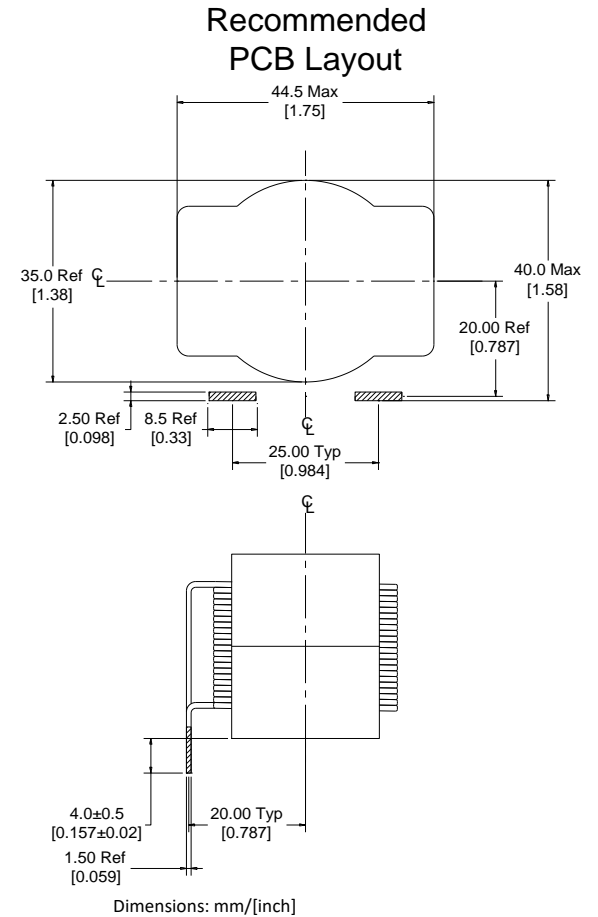
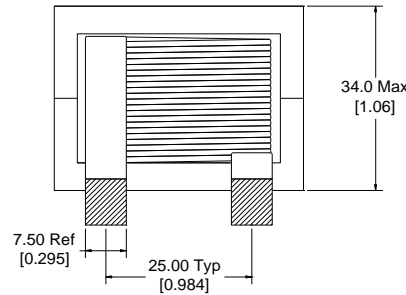
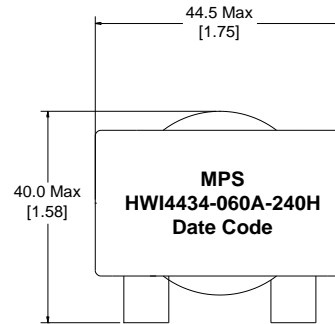

#### Notice of Proprietary Property

These drawings and specifications are the property of MPS and shall not be, reproduced, copied or used as the basis of manufacture of sale of apparatus without express written authorization

<b>Dimensions</b> Unless otherwise specified .XX ± 0.254mm [.010"] .XXX ± 0.13mm [.005"]		DRAWN BY: CHECKED BY:	MIG KC	17-Mar-16 18-Mar-16	SIZE <b>A</b>	Part Number <b>HWI4434-060A-240H</b>	REV <b>C</b>
WEIGHT: 250 gms						SHEET: 1 OF 2	



MPS INDUSTRIES, INC.

[www.mpsind.com](http://www.mpsind.com)

Tel: (310) 325-1043 Fax: (310) 325-1044

Description

**Helical Wound Inductor**

Rev	Description	By	Date
B	Released for Production	MIG	17-Mar-16
C	Updated pin dimensions and DC bias graph	AG	21-Sep-20

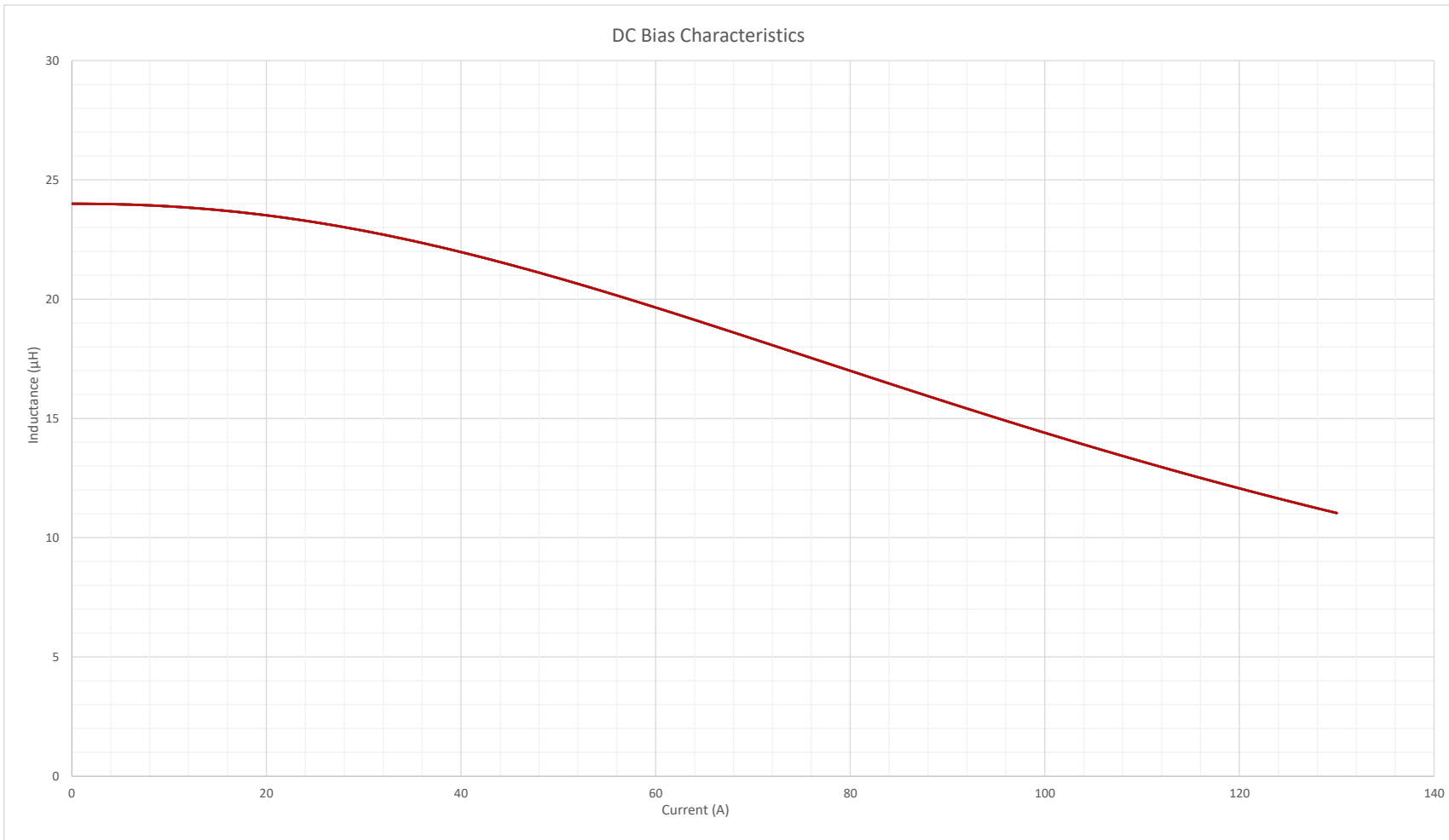

**Notice of Proprietary Property**

These drawings and specifications are the property of MPS and shall not be, reproduced, copied or used as the basis of manufacture of sale of apparatus without express written authorization



**MPS INDUSTRIES, INC.**

www.mpsind.com

Tel: (310) 325-1043 Fax: (310) 325-1044

Description

**Helical Wound Inductor**

**Dimensions**  
Unless otherwise specified  
.XX ± 0.254mm [.010"]  
.XXX ± 0.13mm [.005"]

DRAWN BY:  
CHECKED BY:

MIG  
KC

17-Mar-16  
18-Mar-16

SIZE  
**A**

Part Number

**HWI4434-060A-240H**

REV

**C**

SCALE: X:X

WEIGHT: 250 gms

SHEET: 2 OF 2