

Rev	Description	By	Date
B	Released for Production	MIG	17-Mar-16
C	Corrected pin dimensions and DC bias graph	AG	17-Sep-20

### ELECTRICAL SPECIFICATIONS @ 25°C

L:	29μH±15% @ 10kHz, 1Vrms
Isat:	ΔL ≤ 10% @31A ΔL ≤ 30% @61A
Irms:	ΔT ≤ 20°C @ 29A ΔT ≤ 40°C @ 44A
DCR:	3.0mΩ Max
Hipot:	500Vdc, 1mA, 5s, wdg to core
Insulation Class:	Class H 180°C
RoHS Compliant:	Yes

### SCHEMATIC

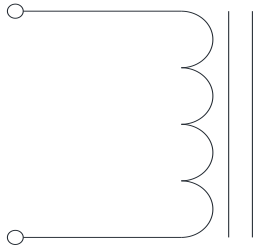

### MARKING

MPS  
HWI4427-044A-290V\_REV#  
Date Code

### DIMENSIONS

### Recommended PCB Layout

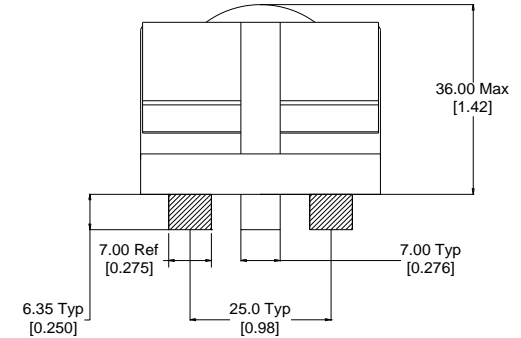
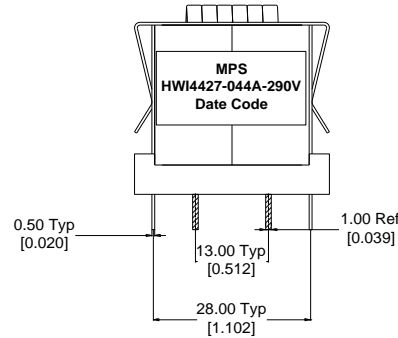
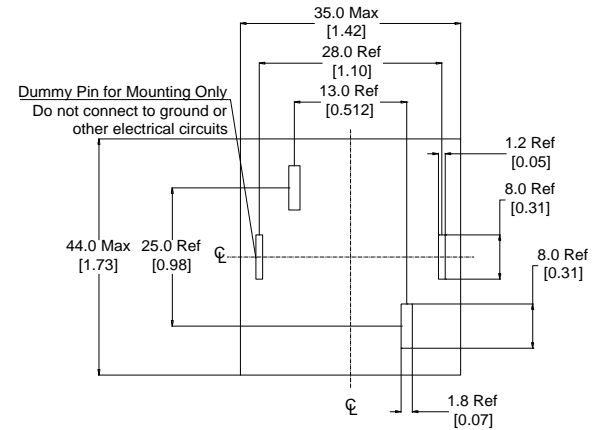
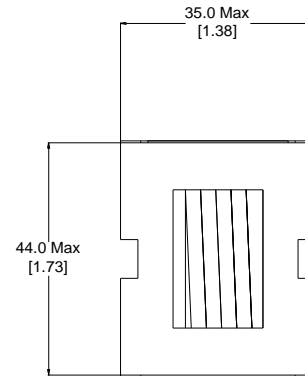

Dimensions: mm/[inch]

#### Notice of Proprietary Property

These drawings and specifications are the property of MPS and shall not be, reproduced, copied or used as the basis of manufacture of sale of apparatus without express written authorization

Dimensions Unless otherwise specified .XX ± 0.254mm [.010"] .XXX ± 0.13mm [.005"]	DRAWN BY:	MIG	17-Mar-16	SIZE	Part Number	REV
	CHECKED BY:	KC	18-Mar-16	<b>A</b>	<b>HWI4427-044A-290V</b>	<b>C</b>



MPS INDUSTRIES, INC.

[www.mpsind.com](http://www.mpsind.com)

Tel: (310) 325-1043 Fax: (310) 325-1044

Description

**Helical Wound Inductor**

WEIGHT: 200 gms

SHEET: 1 OF 2

Rev	Description	By	Date
B	Released for Production	MIG	17-Mar-16
C	Corrected pin dimensions and DC bias graph	AG	17-Sep-20

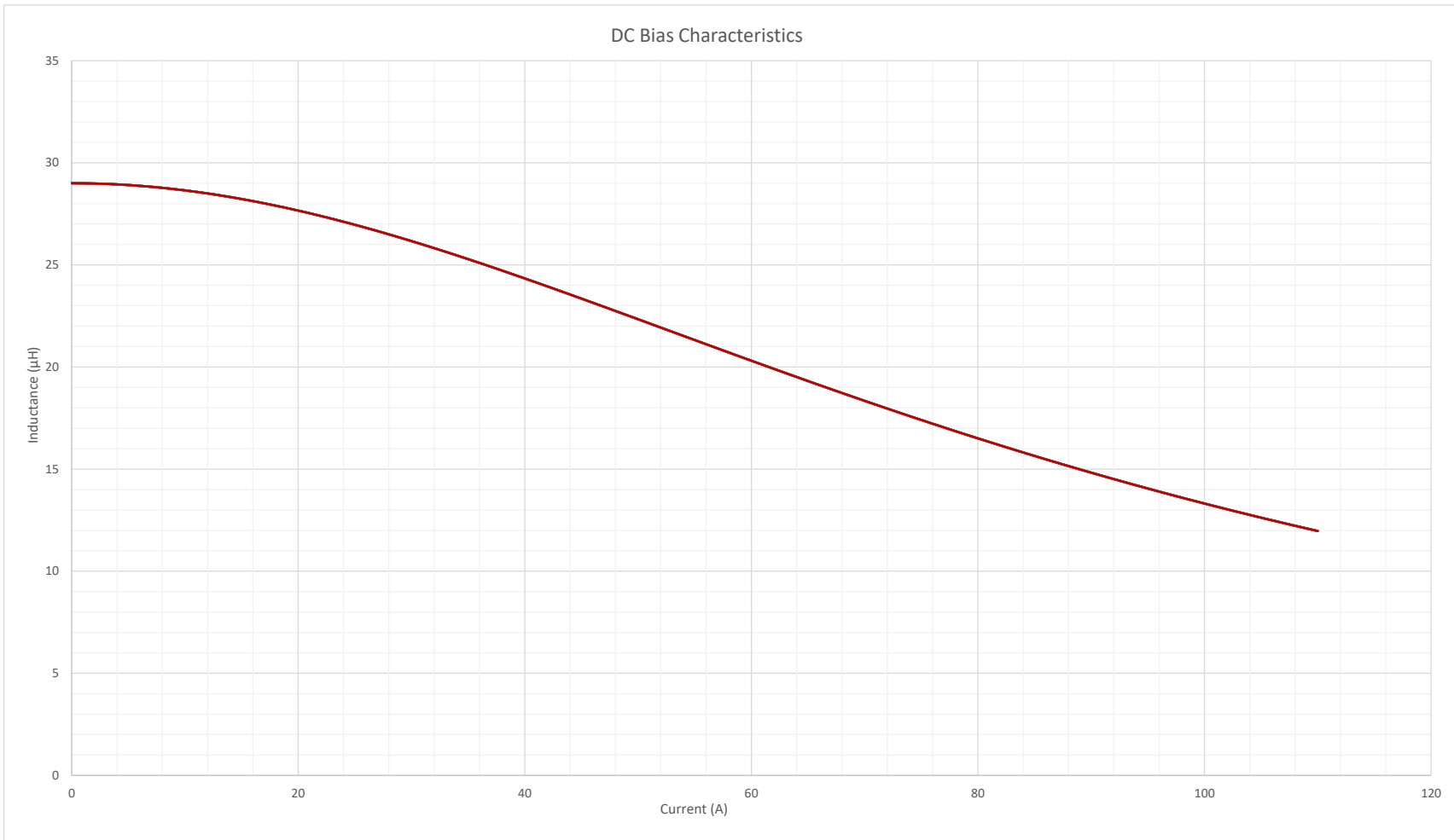

**Notice of Proprietary Property**

These drawings and specifications are the property of MPS and shall not be reproduced, copied or used as the basis of manufacture or sale of apparatus without express written authorization



**MPS INDUSTRIES, INC.**

www.mpsind.com

Tel: (310) 325-1043 Fax: (310) 325-1044

Description

**Helical Wound Inductor**

**Dimensions**  
Unless otherwise specified  
.XX ± 0.254mm [.010"]  
.XXX ± 0.13mm [.005"]

DRAWN BY:  
CHECKED BY:

MIG  
KC

17-Mar-16  
18-Mar-16

SIZE  
**A**

Part Number

**HWI4427-044A-290V**

REV

**C**

SCALE: X:X

WEIGHT: 200 gms

SHEET: 2 OF 2