

Rev	Description	By	Date
B	Released for Production	MIG	17-Mar-16
C	Corrected pin dimensions and DC bias graph	AG	17-Sep-20

### ELECTRICAL SPECIFICATIONS @ 25°C

L:	30μH±15% @ 10kHz, 1Vrms
Isat:	ΔL ≤ 10% @46A ΔL ≤ 30% @82A
Irms:	ΔT ≤ 20°C @ 25A ΔT ≤ 40°C @ 38A
DCR:	4.2mΩ Max
Hipot:	500Vdc, 1mA, 5s, wdg to core
Insulation Class:	Class H 180°C
RoHS Compliant:	Yes

### SCHEMATIC

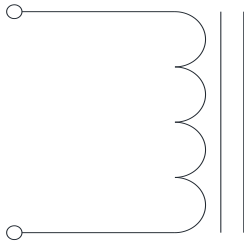

### MARKING

MPS  
HWI4427-038A-300V\_REV#  
Date Code

### DIMENSIONS

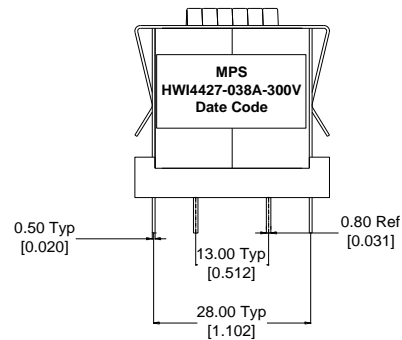
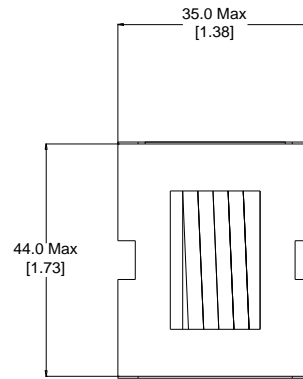

### Recommended PCB Layout

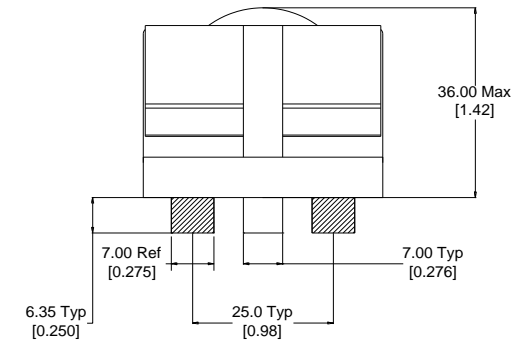
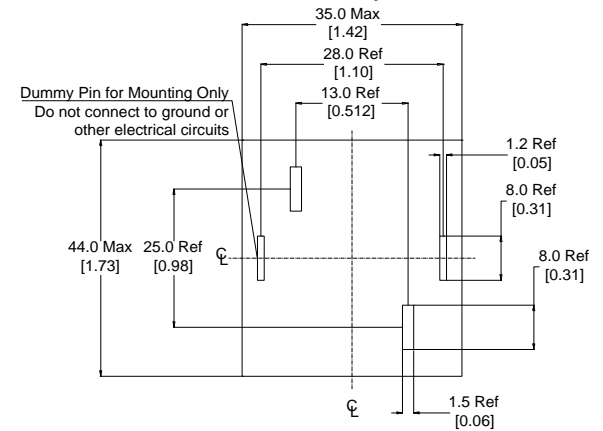

Dimensions: mm/[inch]

#### Notice of Proprietary Property

These drawings and specifications are the property of MPS and shall not be, reproduced, copied or used as the basis of manufacture of sale of apparatus without express written authorization

<b>Dimensions</b> Unless otherwise specified .XX ± 0.254mm [.010"] .XXX ± 0.13mm [.005"]	DRAWN BY: CHECKED BY:	MIG KC	17-Mar-16 18-Mar-16	SIZE <b>A</b>
---	--------------------------	-----------	------------------------	------------------



MPS INDUSTRIES, INC.

[www.mpsind.com](http://www.mpsind.com)

Tel: (310) 325-1043 Fax: (310) 325-1044

Description

**Helical Wound Inductor**

Part Number

**HWI4427-038A-300V**

REV

**C**

WEIGHT: 200 gms

SHEET: 1 OF 2

Rev	Description	By	Date
B	Released for Production	MIG	17-Mar-16
C	Corrected pin dimensions and DC bias graph	AG	17-Sep-20

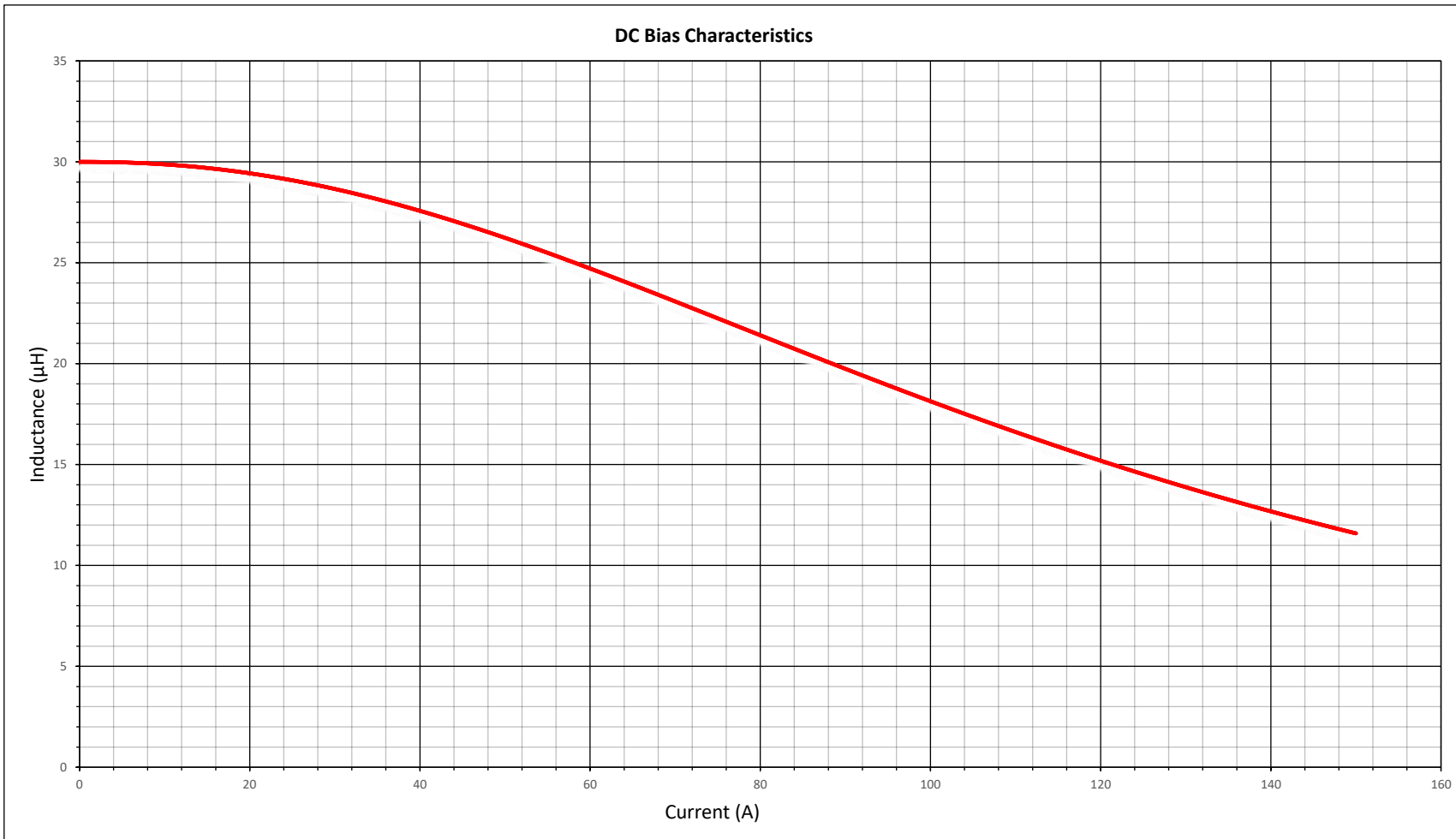

**Notice of Proprietary Property**

These drawings and specifications are the property of MPS and shall not be reproduced, copied or used as the basis of manufacture of sale of apparatus without express written authorization



**MPS INDUSTRIES, INC.**

www.mpsind.com

Tel: (310) 325-1043 Fax: (310) 325-1044

Description

**Helical Wound Inductor**

**Dimensions**  
 Unless otherwise specified  
 .XX ± 0.254mm [.010"]  
 .XXX ± 0.13mm [.005"]

DRAWN BY:  
 CHECKED BY:

MIG  
 KC

17-Mar-16  
 18-Mar-16

SIZE  
**A**

Part Number

**HWI4427-038A-300V**

REV

**C**

SCALE: X:X

WEIGHT: 200 gms

SHEET: 2 OF 2